

# IberPrecis S.L.

VAST



# Certificado

Normativa de aplicación **EN 9100:2003**  
equivalente a AS 9100 y JSQ 9100, incluye la Norma ISO 9001:2000

Nº registro certificado 01 117 94370

TÜV Rheinland Cert GmbH certifica:

Titular del certificado: **IBER PRECIS, S.L.**  
Polígono Pignatelli, nave 17  
E - 50410 Cuarte de Huerva

Ámbito de aplicación: Mecanizados de precisión y montajes de conjuntos para aplicaciones en los sectores aeronáutico, defensa e industrial

Mediante auditoría realizada a base de EN 9104, según consta en el informe nº 94370, se verificó el cumplimiento de los requisitos recogidos en la norma EN 9100:2003.

La fecha límite para la auditoría de seguimiento es 08-04 (dd.mm).

Validez: Este certificado es válido desde 2009-06-08 hasta 2012-06-07.

Cologne, 2009-06-09

*K. Dieckes*  
TÜV Rheinland Cert GmbH  
Am Grauen Stein · 51105 Köln



www.tuv.com



TÜVRheinland  
Precisely Right

# Certificado

Normativa de aplicación **ISO 9001:2008**

Nº registro certificado 01 100 94370

TÜV Rheinland Cert GmbH certifica:

Titular del certificado: **IBER PRECIS, S.L.**  
Polígono Pignatelli, nave 17  
E - 50410 Cuarte de Huerva

Ámbito de aplicación: Mecanizados de precisión y montajes de conjuntos para aplicaciones en los sectores aeronáutico, defensa e industrial

Mediante auditoría realizada, según consta en el informe nº 94370 se verificó el cumplimiento de los requisitos recogidos en la norma ISO 9001:2008.

La fecha límite para la auditoría de seguimiento es 08-04 (dd.mm).

Validez: Este certificado es válido desde 2009-06-08 hasta 2012-06-07.

Cologne, 2009-06-09

*K. Dieckes*  
TÜV Rheinland Cert GmbH  
Am Grauen Stein · 51105 Köln



www.tuv.com



TÜVRheinland  
Precisely Right

**IBERPRECIS empresa de mecanizado, fabricación y montaje de conjuntos mecánicos...**, para gestionar y dar al cliente una solución global contamos con INGENIERÍA externa, LABORATORIO METROLÓGICO interno y 4 ÁREAS DE GESTIÓN. Todo ello esta coordinado por Gerencia, avalado por una experiencia de mas de 30 años en mecanización y montajes.

## 1. ÁREAS DE GESTIÓN:

Área financiera para gestión y optimización de los recursos financieros.

Área comercial con Departamento independiente de comercio exterior.

Área de Gestión de Calidad para garantizar el cumplimiento de las normas, (ISO 9001:200) (EN-9100).

Área de Producción:

- Oficina técnica especializada en desarrollo y confección de rutas y procesos.
- Compras tanto nacionales como internacionales, consta de un departamento para Materias primas y otro para Subcontratación. Es importante destacar esta capacidad para optimizar costos y localizar los componentes que no somos capaces de fabricar por precio, capacidad, estrategia o plazo.
- Logística un técnico coordina nuestros almacenes para asegurar plazos pactados con el cliente considerando fechas previstas de proveedores y fabricación.
- Fabricación englobada en tres departamentos para suministrar al cliente producto terminado: Mecanización en centros CNC, tornos CNC, Rectificadoras. Tamaño máximo 700mm. y diámetro 500mm. Acabado Final para superficies mediante electro pulidos, bombeados y chorreados. Montaje de conjuntos para suministro directo a líneas de montaje.

**2. LABORATORIO METROLÓGICO** (Business Partner de ZEISS), garantizamos el control dimensional de nuestro fabricado mediante informes de medición. Lo avalamos con nuestros técnicos acreditados por AUKOM (Formación en metrología por coordenadas) y nuestro parque de metrología destacado por :

- Medición y análisis de geometrías internas y externas por rayos X (Tomografía computerizada).
- Scanning por palpación en máquina semiautomática de medición por coordenadas.

**3.INGENIERIA**, Para completar la cadena de valor y ofrecer una solución integral a nuestros clientes contamos con una Ingeniería, asociada, con 35 personas y software en CATIA V5, PROENGINEER, UNIGRAPHICS, SOLIDWORK, SOLIDEDGE, INVENTOR AUTOCAD, ABAQUS, MSC LAMINATE, ADAMS, DYTRAN, LS-DYNA, NASTRAN-PATRAN. Especializada en:

- Ingeniería de Calculo estático, dinámico, lineal, no lineal mediante FEM. Ensayos de validación e instrumentación.
- Ingeniería de producto. Diseño y desarrollo de proyectos mecánicos, diseño en plástico y material compuesto.
- Ingeniería de Producción. Diseño y fabricación de utillajes, maquinaria, líneas de montaje, calibres de control, etc.



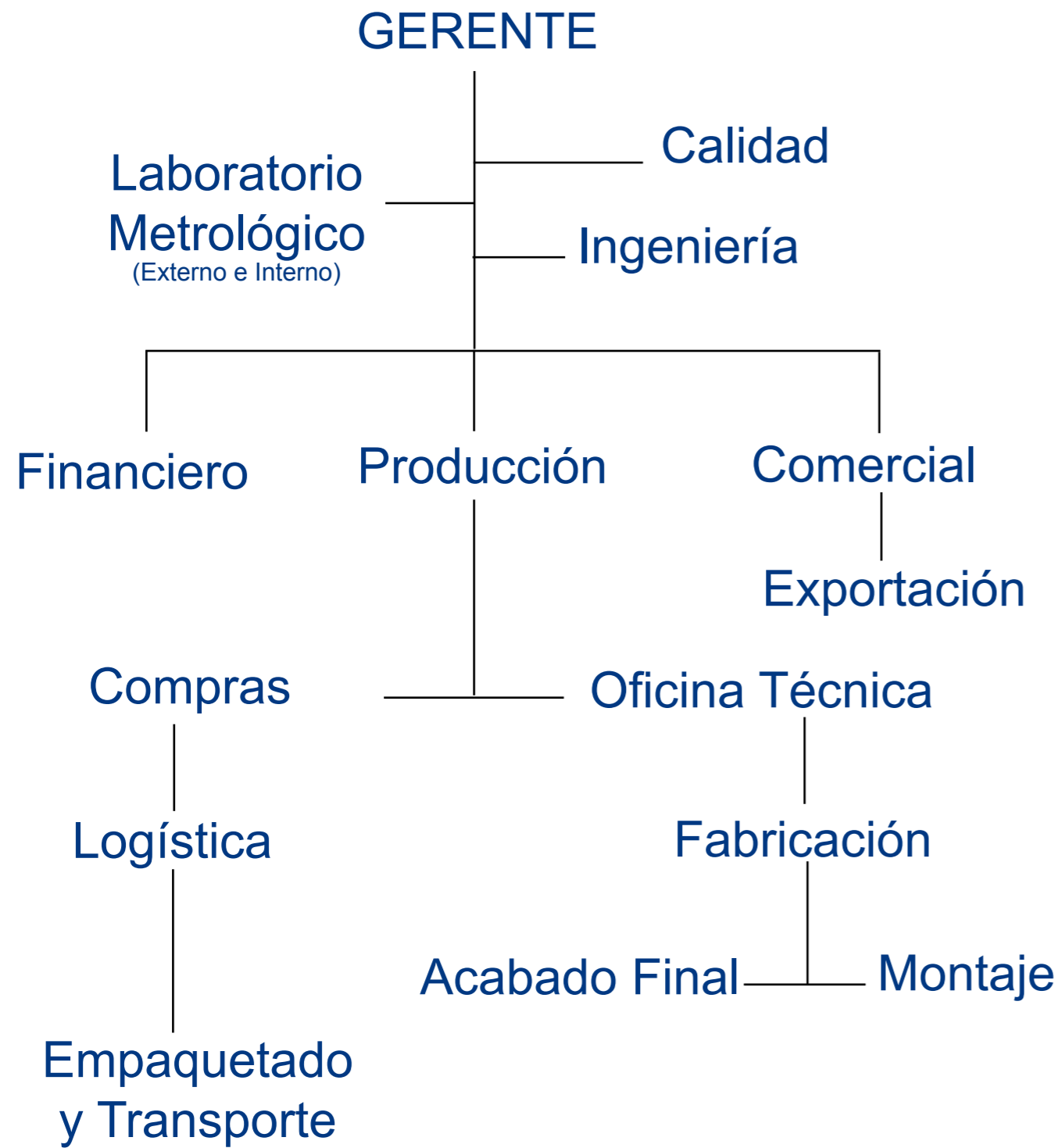

**Departamento de Calidad**

1 Ingeniero Industrial

**Departamento Financiero**

1 Director financiero

1 Auxiliar administrativo

**Departamento de Compras**

1 Comprador internacional

1 Comprador subcontratista

**Departamento Comercial**

1 Director comercial

1 Director exportaciones

**Oficina Técnica**

3 Desarrollo de procesos y hoja de ruta

Software: CAD-CAM (VISI-SERIES 14.0)

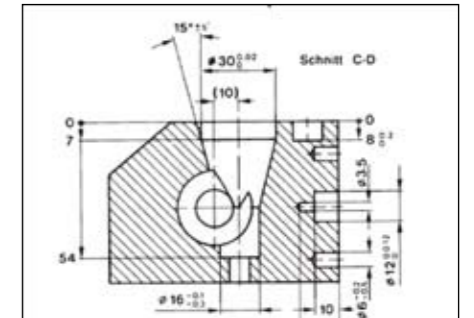

# Ingeniería

## Ingeniería de Cálculo:

Cálculo estático, dinámico, lineal, no lineal mediante FEM. Ensayos de validación e instrumentación.

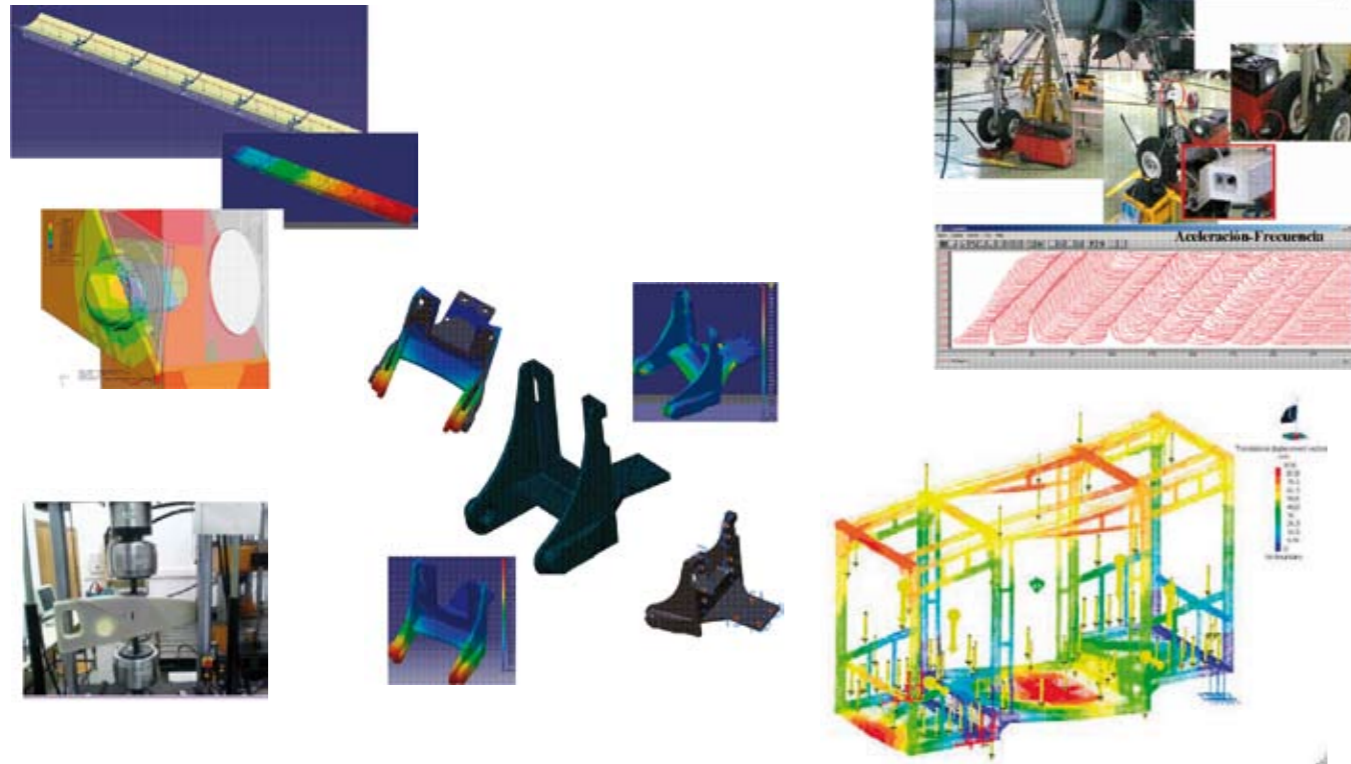

## Ingeniería de Producción:

Diseño y fabricación de utillajes, máquinas, líneas de montaje, calibres de control, etc.

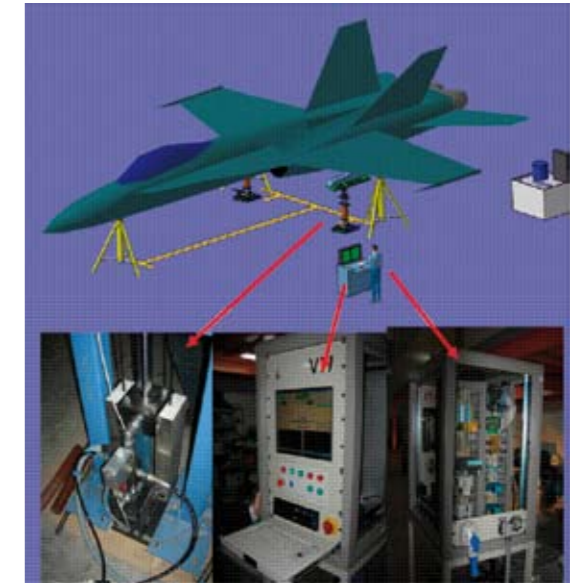

## Ingeniería de Producto:

Diseño y desarrollo de proyectos mecánicos, diseño en plástico y material compuesto.

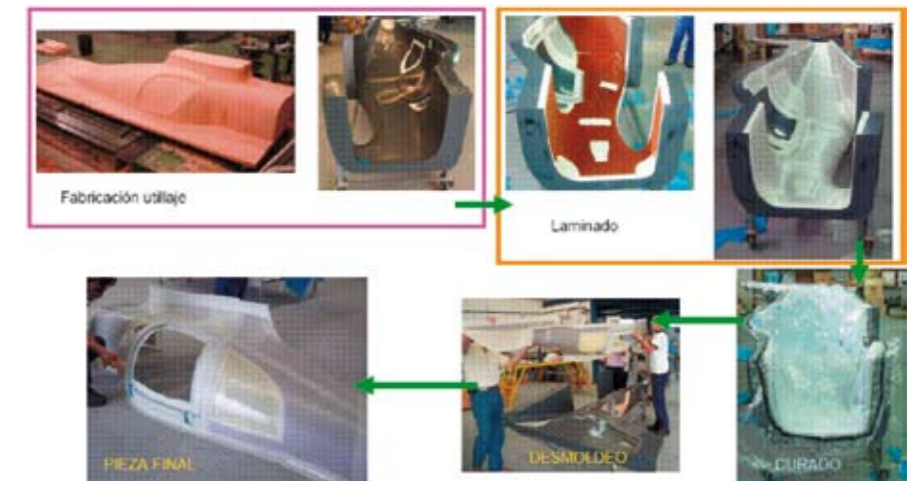
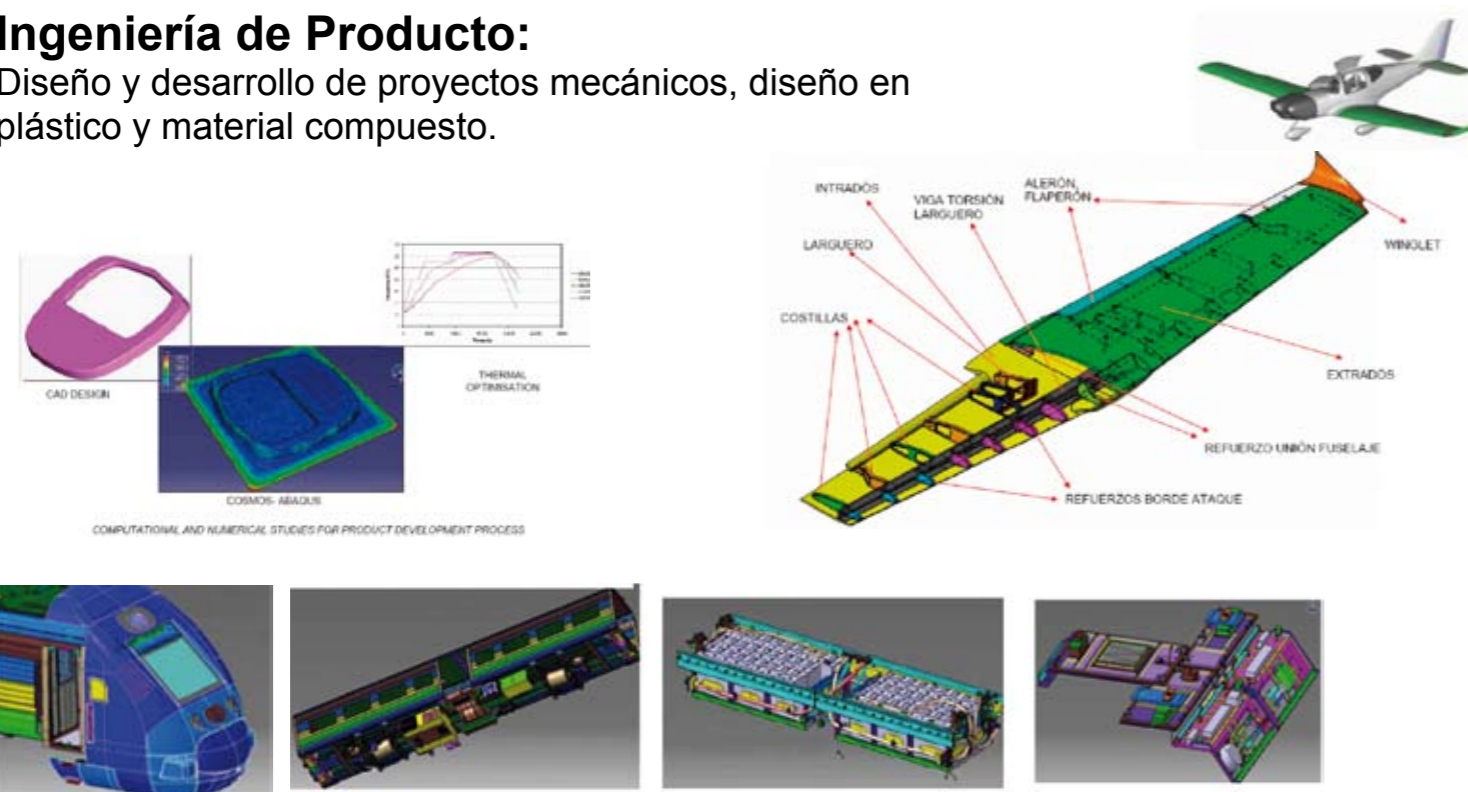

## SOFTWARE:

- CATIA V5,
- PROENGINEER
- UNIGRAPHICS
- SOLIDWORK
- SOLIDEDGE
- INVENTOR AUTOCAD
- ABAQUS
- MSC LAMINATE
- ADAMS
- DYTRAN
- LS-DYNA
- NASTRAN-PATRAN

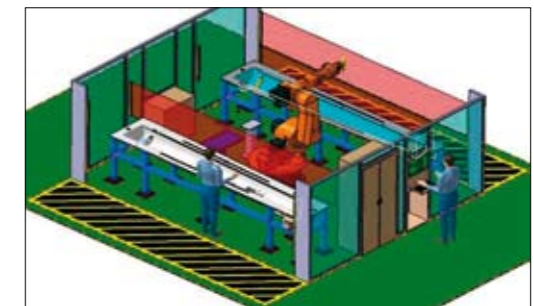

# Laboratorio Metrológico

• Personal con certificación a AUKOM.

- Ingeniero Industrial
- Técnicos acreditados

• Softwares:

- CALYPSO
- VGStudio MAX

• Equipos:

- Máquina Semiautomática de medición por coordenadas con tecnología de scanning por palpación ZEISS CONTURA G2 (700 x 1000 x 600 mm)
- Máquina de palpación manual BROWN & SHARPE (400 X 500 X 300 mm)
- Columnas verticales hasta 600 mm.(TRIMOS, TESA, MANSER).
- Rugosímetros.
- Medición de durezas. HB, HRC, HS.
- Proyectores de perfiles (Mitutoyo, Baty).
- Detector de grietas por partículas magnéticas.
- Servicios de Tomografiado.  
(Tomografía Computarizada para inspección externa e interna)



Formados por AUKOM



## Metrotomografía®

Medición y análisis de geometrías internas por rayos X (Tomografía computarizada):

Análisis de poros y defectos, comprobación de montajes y visualización interna sin necesidad de destrucción.

Mediciones completas y comparaciones de pieza con sólido CAD.

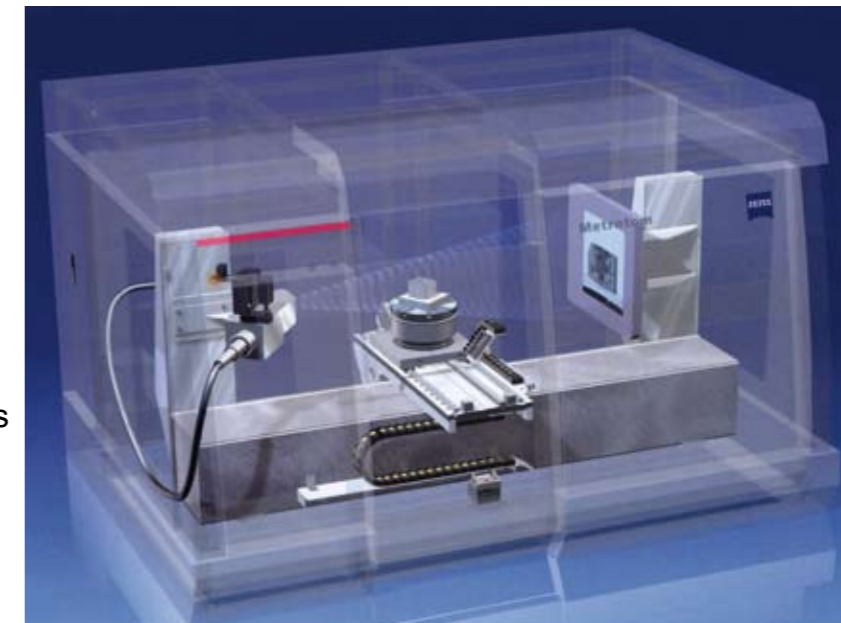

Comparación real/CAD



Análisis de poros

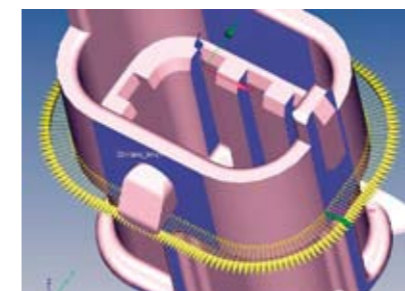

Medición de geometrías

Carl Zeiss		Fecha: 30 Septiembre 2009					
Cajón: 44 36 16		Escala: 10.000					
Número Pila:	Modelo:	Número de pieza:	Operador:				
11	CON1_52	Z 40116	Master				
Plano de perfil: 140.00							
Redondeo (R): 0.125(0.1)							
10.000 mm a							
No.	Dimension:	Tolerancia:	Pos.	Unid.	Def/Tip.	Def. 3-D	Def.
1	Radio: R10	±0.05	201	30	100%	Circ	0.10

ZEISS Calypso					
Valor real	Valor nom.	Tol. sup.	Tol. inf.	Desvio	
38.1571	38.0000	0.1000	0.0000	0.0071	
62.9537	63.0000	0.0000	-0.1000	-0.0463	
62.9970	63.0000	0.0000	-0.1000	-0.0030	
-3.5488	-3.5000	0.0000	-0.0000	0.0194	
-0.0417	-0.0000	0.0000	-0.0000	0.0393	
28.8888	29.0000	0.1000	-0.1000	-0.0102	
28.8500	29.0000	0.1000	-0.1000	-0.0001	
69.7229	69.0000	0.0000	-0.0000	0.7229	
0.0194	0.0000	0.0000	0.0000	0.0194	
47.2052	46.0000	0.1000	-0.2000	0.2052	

Informes de resultados





# fabricación

Departamento de fabricación

## Trazabilidad

Para cada pedido recibido generamos un documento interno con un código. En este documento incluimos toda la documentación requerida:

- Normas
- Materia prima
- Proceso (hoja de ruta)
- Mediciones

Grabamos este código interno con todo lo requerido para garantizar la trazabilidad.

## Ingeniería de proceso

Antes de fabricar cualquier pieza la procesamos y desarrollamos en CAD CAM. De este modo conseguimos las mejores condiciones y procesos para mecanizar asegurando que todas las operaciones serán las correctas.

## Cost Savings

Calibración y análisis de las herramientas de corte con visión artificial (PARLEC). Esto nos aporta la optimización del consumo de herramientas, incremento de la productividad y ahorro de energía, para ser más competitivos.



Departamento Logística



Departamento de montaje

ORDEN DE FABRICACION		Nº PROYECTO PA0002																																																																																																																																																																																																																																																																																																																																																																																																																									
FECHA DE ELABORACION	06/05/2014	FECHA DE EJECUCION	06/05/2014																																																																																																																																																																																																																																																																																																																																																																																																																								
FECHA DE RECEPCION	06/05/2014	FECHA DE ENTREGA	06/05/2014																																																																																																																																																																																																																																																																																																																																																																																																																								
MATERIAL: 77701403180-PPQ-A-229 (6180180)		CANTIDAD: 100																																																																																																																																																																																																																																																																																																																																																																																																																									
Nº MOLD: 10101		Nº MOLD: 10101																																																																																																																																																																																																																																																																																																																																																																																																																									
MATERIAL: 332253880/336		Nº MOLD: 10101																																																																																																																																																																																																																																																																																																																																																																																																																									
MATERIAL: 332253880/336		Nº MOLD: 10101																																																																																																																																																																																																																																																																																																																																																																																																																									
<table border="1"> <thead> <tr> <th colspan="2">HOJA DE RUTA</th> <th colspan="2">Nº PROYECTO PA0002</th> </tr> </thead> <tbody> <tr> <td>OPERACION</td> <td>DESCRIPCION DE LA OPERACION</td> <td>FECHA DE EJECUCION</td> <td>FECHA DE ENTREGA</td> </tr> <tr> <td>000 001</td> <td>PREPARACION DE LA MATERIA PRIMA</td> <td></td> <td></td> </tr> <tr> <td>000 002</td> <td>OPERACION DE MONTAJE DE LA PIEZA</td> <td></td> <td></td> </tr> <tr> <td>000 003</td> <td>OPERACION DE MONTAJE DE LA PIEZA</td> <td></td> <td></td> </tr> <tr> <td>000 004</td> <td>OPERACION DE MONTAJE DE LA PIEZA</td> <td></td> <td></td> </tr> <tr> <td>000 005</td> <td>OPERACION DE MONTAJE DE LA PIEZA</td> <td></td> <td></td> </tr> <tr> <td>000 006</td> <td>OPERACION DE MONTAJE DE LA PIEZA</td> <td></td> <td></td> </tr> <tr> <td>000 007</td> <td>OPERACION DE MONTAJE DE LA PIEZA</td> <td></td> <td></td> </tr> <tr> <td>000 008</td> <td>OPERACION DE MONTAJE DE LA PIEZA</td> <td></td> <td></td> </tr> <tr> <td>000 009</td> <td>OPERACION DE MONTAJE DE LA PIEZA</td> <td></td> <td></td> </tr> <tr> <td>000 010</td> <td>OPERACION DE MONTAJE DE LA PIEZA</td> <td></td> <td></td> </tr> <tr> <td>000 011</td> <td>OPERACION DE MONTAJE DE LA PIEZA</td> <td></td> <td></td> </tr> <tr> <td>000 012</td> <td>OPERACION DE MONTAJE DE LA PIEZA</td> <td></td> <td></td> </tr> <tr> <td>000 013</td> <td>OPERACION DE MONTAJE DE LA PIEZA</td> <td></td> <td></td> </tr> <tr> <td>000 014</td> <td>OPERACION DE MONTAJE DE LA PIEZA</td> <td></td> <td></td> </tr> <tr> <td>000 015</td> <td>OPERACION DE MONTAJE DE LA PIEZA</td> <td></td> <td></td> </tr> <tr> <td>000 016</td> <td>OPERACION DE MONTAJE DE LA PIEZA</td> <td></td> <td></td> </tr> <tr> <td>000 017</td> <td>OPERACION DE MONTAJE DE LA PIEZA</td> <td></td> <td></td> </tr> <tr> <td>000 018</td> <td>OPERACION DE MONTAJE DE LA PIEZA</td> <td></td> <td></td> </tr> <tr> <td>000 019</td> <td>OPERACION DE MONTAJE DE LA PIEZA</td> <td></td> <td></td> </tr> <tr> <td>000 020</td> <td>OPERACION DE MONTAJE DE LA PIEZA</td> <td></td> <td></td> </tr> <tr> <td>000 021</td> <td>OPERACION DE MONTAJE DE LA PIEZA</td> <td></td> <td></td> </tr> <tr> <td>000 022</td> <td>OPERACION DE MONTAJE DE LA PIEZA</td> <td></td> <td></td> </tr> <tr> <td>000 023</td> <td>OPERACION DE MONTAJE DE LA PIEZA</td> <td></td> <td></td> </tr> <tr> <td>000 024</td> <td>OPERACION DE MONTAJE DE LA PIEZA</td> <td></td> <td></td> </tr> <tr> <td>000 025</td> <td>OPERACION DE MONTAJE DE LA PIEZA</td> <td></td> <td></td> </tr> <tr> <td>000 026</td> <td>OPERACION DE MONTAJE DE LA PIEZA</td> <td></td> <td></td> </tr> <tr> <td>000 027</td> <td>OPERACION DE MONTAJE DE LA PIEZA</td> <td></td> <td></td> </tr> <tr> <td>000 028</td> <td>OPERACION DE MONTAJE DE LA PIEZA</td> <td></td> <td></td> </tr> <tr> <td>000 029</td> <td>OPERACION DE MONTAJE DE LA PIEZA</td> <td></td> <td></td> </tr> <tr> <td>000 030</td> <td>OPERACION DE MONTAJE DE LA PIEZA</td> <td></td> <td></td> </tr> <tr> <td>000 031</td> <td>OPERACION DE MONTAJE DE LA PIEZA</td> <td></td> <td></td> </tr> <tr> <td>000 032</td> <td>OPERACION DE MONTAJE DE LA PIEZA</td> <td></td> <td></td> </tr> <tr> <td>000 033</td> <td>OPERACION DE MONTAJE DE LA PIEZA</td> <td></td> <td></td> </tr> <tr> <td>000 034</td> <td>OPERACION DE MONTAJE DE LA PIEZA</td> <td></td> <td></td> </tr> <tr> <td>000 035</td> <td>OPERACION DE MONTAJE DE LA PIEZA</td> <td></td> <td></td> </tr> <tr> <td>000 036</td> <td>OPERACION DE MONTAJE DE LA PIEZA</td> <td></td> <td></td> </tr> <tr> <td>000 037</td> <td>OPERACION DE MONTAJE DE LA PIEZA</td> <td></td> <td></td> </tr> <tr> <td>000 038</td> <td>OPERACION DE MONTAJE DE LA PIEZA</td> <td></td> <td></td> </tr> <tr> <td>000 039</td> <td>OPERACION DE MONTAJE DE LA PIEZA</td> <td></td> <td></td> </tr> <tr> <td>000 040</td> <td>OPERACION DE MONTAJE DE LA PIEZA</td> <td></td> <td></td> </tr> <tr> <td>000 041</td> <td>OPERACION DE MONTAJE DE LA PIEZA</td> <td></td> <td></td> </tr> <tr> <td>000 042</td> <td>OPERACION DE MONTAJE DE LA PIEZA</td> <td></td> <td></td> </tr> <tr> <td>000 043</td> <td>OPERACION DE MONTAJE DE LA PIEZA</td> <td></td> <td></td> </tr> <tr> <td>000 044</td> <td>OPERACION DE MONTAJE DE LA PIEZA</td> <td></td> <td></td> </tr> <tr> <td>000 045</td> <td>OPERACION DE MONTAJE DE LA PIEZA</td> <td></td> <td></td> </tr> <tr> <td>000 046</td> <td>OPERACION DE MONTAJE DE LA PIEZA</td> <td></td> <td></td> </tr> <tr> <td>000 047</td> <td>OPERACION DE MONTAJE DE LA PIEZA</td> <td></td> <td></td> </tr> <tr> <td>000 048</td> <td>OPERACION DE MONTAJE DE LA PIEZA</td> <td></td> <td></td> </tr> <tr> <td>000 049</td> <td>OPERACION DE MONTAJE DE LA PIEZA</td> <td></td> <td></td> </tr> <tr> <td>000 050</td> <td>OPERACION DE MONTAJE DE LA PIEZA</td> <td></td> <td></td> </tr> <tr> <td>000 051</td> <td>OPERACION DE MONTAJE DE LA PIEZA</td> <td></td> <td></td> </tr> <tr> <td>000 052</td> <td>OPERACION DE MONTAJE DE LA PIEZA</td> <td></td> <td></td> </tr> <tr> <td>000 053</td> <td>OPERACION DE MONTAJE DE LA PIEZA</td> <td></td> <td></td> </tr> <tr> <td>000 054</td> <td>OPERACION DE MONTAJE DE LA PIEZA</td> <td></td> <td></td> </tr> <tr> <td>000 055</td> <td>OPERACION DE MONTAJE DE LA PIEZA</td> <td></td> <td></td> </tr> <tr> <td>000 056</td> <td>OPERACION DE MONTAJE DE LA PIEZA</td> <td></td> <td></td> </tr> <tr> <td>000 057</td> <td>OPERACION DE MONTAJE DE LA PIEZA</td> <td></td> <td></td> </tr> <tr> <td>000 058</td> <td>OPERACION DE MONTAJE DE LA PIEZA</td> <td></td> <td></td> </tr> <tr> <td>000 059</td> <td>OPERACION DE MONTAJE DE LA PIEZA</td> <td></td> <td></td> </tr> <tr> <td>000 060</td> <td>OPERACION DE MONTAJE DE LA PIEZA</td> <td></td> <td></td> </tr> <tr> <td>000 061</td> <td>OPERACION DE MONTAJE DE LA PIEZA</td> <td></td> <td></td> </tr> <tr> <td>000 062</td> <td>OPERACION DE MONTAJE DE LA PIEZA</td> <td></td> <td></td> </tr> <tr> <td>000 063</td> <td>OPERACION DE MONTAJE DE LA PIEZA</td> <td></td> <td></td> </tr> <tr> <td>000 064</td> <td>OPERACION DE MONTAJE DE LA PIEZA</td> <td></td> <td></td> </tr> <tr> <td>000 065</td> <td>OPERACION DE MONTAJE DE LA PIEZA</td> <td></td> <td></td> </tr> <tr> <td>000 066</td> <td>OPERACION DE MONTAJE DE LA PIEZA</td> <td></td> <td></td> </tr> <tr> <td>000 067</td> <td>OPERACION DE MONTAJE DE LA PIEZA</td> <td></td> <td></td> </tr> <tr> <td>000 068</td> <td>OPERACION DE MONTAJE DE LA PIEZA</td> <td></td> <td></td> </tr> <tr> <td>000 069</td> <td>OPERACION DE MONTAJE DE LA PIEZA</td> <td></td> <td></td> </tr> <tr> <td>000 070</td> <td>OPERACION DE MONTAJE DE LA PIEZA</td> <td></td> <td></td> </tr> <tr> <td>000 071</td> <td>OPERACION DE MONTAJE DE LA PIEZA</td> <td></td> <td></td> </tr> <tr> <td>000 072</td> <td>OPERACION DE MONTAJE DE LA PIEZA</td> <td></td> <td></td> </tr> <tr> <td>000 073</td> <td>OPERACION DE MONTAJE DE LA PIEZA</td> <td></td> <td></td> </tr> <tr> <td>000 074</td> <td>OPERACION DE MONTAJE DE LA PIEZA</td> <td></td> <td></td> </tr> <tr> <td>000 075</td> <td>OPERACION DE MONTAJE DE LA PIEZA</td> <td></td> <td></td> </tr> <tr> <td>000 076</td> <td>OPERACION DE MONTAJE DE LA PIEZA</td> <td></td> <td></td> </tr> <tr> <td>000 077</td> <td>OPERACION DE MONTAJE DE LA PIEZA</td> <td></td> <td></td> </tr> <tr> <td>000 078</td> <td>OPERACION DE MONTAJE DE LA PIEZA</td> <td></td> <td></td> </tr> <tr> <td>000 079</td> <td>OPERACION DE MONTAJE DE LA PIEZA</td> <td></td> <td></td> </tr> <tr> <td>000 080</td> <td>OPERACION DE MONTAJE DE LA PIEZA</td> <td></td> <td></td> </tr> <tr> <td>000 081</td> <td>OPERACION DE MONTAJE DE LA PIEZA</td> <td></td> <td></td> </tr> <tr> <td>000 082</td> <td>OPERACION DE MONTAJE DE LA PIEZA</td> <td></td> <td></td> </tr> <tr> <td>000 083</td> <td>OPERACION DE MONTAJE DE LA PIEZA</td> <td></td> <td></td> </tr> <tr> <td>000 084</td> <td>OPERACION DE MONTAJE DE LA PIEZA</td> <td></td> <td></td> </tr> <tr> <td>000 085</td> <td>OPERACION DE MONTAJE DE LA PIEZA</td> <td></td> <td></td> </tr> <tr> <td>000 086</td> <td>OPERACION DE MONTAJE DE LA PIEZA</td> <td></td> <td></td> </tr> <tr> <td>000 087</td> <td>OPERACION DE MONTAJE DE LA PIEZA</td> <td></td> <td></td> </tr> <tr> <td>000 088</td> <td>OPERACION DE MONTAJE DE LA PIEZA</td> <td></td> <td></td> </tr> <tr> <td>000 089</td> <td>OPERACION DE MONTAJE DE LA PIEZA</td> <td></td> <td></td> </tr> <tr> <td>000 090</td> <td>OPERACION DE MONTAJE DE LA PIEZA</td> <td></td> <td></td> </tr> <tr> <td>000 091</td> <td>OPERACION DE MONTAJE DE LA PIEZA</td> <td></td> <td></td> </tr> <tr> <td>000 092</td> <td>OPERACION DE MONTAJE DE LA PIEZA</td> <td></td> <td></td> </tr> <tr> <td>000 093</td> <td>OPERACION DE MONTAJE DE LA PIEZA</td> <td></td> <td></td> </tr> <tr> <td>000 094</td> <td>OPERACION DE MONTAJE DE LA PIEZA</td> <td></td> <td></td> </tr> <tr> <td>000 095</td> <td>OPERACION DE MONTAJE DE LA PIEZA</td> <td></td> <td></td> </tr> <tr> <td>000 096</td> <td>OPERACION DE MONTAJE DE LA PIEZA</td> <td></td> <td></td> </tr> <tr> <td>000 097</td> <td>OPERACION DE MONTAJE DE LA PIEZA</td> <td></td> <td></td> </tr> <tr> <td>000 098</td> <td>OPERACION DE MONTAJE DE LA PIEZA</td> <td></td> <td></td> </tr> <tr> <td>000 099</td> <td>OPERACION DE MONTAJE DE LA PIEZA</td> <td></td> <td></td> </tr> <tr> <td>000 100</td> <td>OPERACION DE MONTAJE DE LA PIEZA</td> <td></td> <td></td> </tr> </tbody> </table>				HOJA DE RUTA		Nº PROYECTO PA0002		OPERACION	DESCRIPCION DE LA OPERACION	FECHA DE EJECUCION	FECHA DE ENTREGA	000 001	PREPARACION DE LA MATERIA PRIMA			000 002	OPERACION DE MONTAJE DE LA PIEZA			000 003	OPERACION DE MONTAJE DE LA PIEZA			000 004	OPERACION DE MONTAJE DE LA PIEZA			000 005	OPERACION DE MONTAJE DE LA PIEZA			000 006	OPERACION DE MONTAJE DE LA PIEZA			000 007	OPERACION DE MONTAJE DE LA PIEZA			000 008	OPERACION DE MONTAJE DE LA PIEZA			000 009	OPERACION DE MONTAJE DE LA PIEZA			000 010	OPERACION DE MONTAJE DE LA PIEZA			000 011	OPERACION DE MONTAJE DE LA PIEZA			000 012	OPERACION DE MONTAJE DE LA PIEZA			000 013	OPERACION DE MONTAJE DE LA PIEZA			000 014	OPERACION DE MONTAJE DE LA PIEZA			000 015	OPERACION DE MONTAJE DE LA PIEZA			000 016	OPERACION DE MONTAJE DE LA PIEZA			000 017	OPERACION DE MONTAJE DE LA PIEZA			000 018	OPERACION DE MONTAJE DE LA PIEZA			000 019	OPERACION DE MONTAJE DE LA PIEZA			000 020	OPERACION DE MONTAJE DE LA PIEZA			000 021	OPERACION DE MONTAJE DE LA PIEZA			000 022	OPERACION DE MONTAJE DE LA PIEZA			000 023	OPERACION DE MONTAJE DE LA PIEZA			000 024	OPERACION DE MONTAJE DE LA PIEZA			000 025	OPERACION DE MONTAJE DE LA PIEZA			000 026	OPERACION DE MONTAJE DE LA PIEZA			000 027	OPERACION DE MONTAJE DE LA PIEZA			000 028	OPERACION DE MONTAJE DE LA PIEZA			000 029	OPERACION DE MONTAJE DE LA PIEZA			000 030	OPERACION DE MONTAJE DE LA PIEZA			000 031	OPERACION DE MONTAJE DE LA PIEZA			000 032	OPERACION DE MONTAJE DE LA PIEZA			000 033	OPERACION DE MONTAJE DE LA PIEZA			000 034	OPERACION DE MONTAJE DE LA PIEZA			000 035	OPERACION DE MONTAJE DE LA PIEZA			000 036	OPERACION DE MONTAJE DE LA PIEZA			000 037	OPERACION DE MONTAJE DE LA PIEZA			000 038	OPERACION DE MONTAJE DE LA PIEZA			000 039	OPERACION DE MONTAJE DE LA PIEZA			000 040	OPERACION DE MONTAJE DE LA PIEZA			000 041	OPERACION DE MONTAJE DE LA PIEZA			000 042	OPERACION DE MONTAJE DE LA PIEZA			000 043	OPERACION DE MONTAJE DE LA PIEZA			000 044	OPERACION DE MONTAJE DE LA PIEZA			000 045	OPERACION DE MONTAJE DE LA PIEZA			000 046	OPERACION DE MONTAJE DE LA PIEZA			000 047	OPERACION DE MONTAJE DE LA PIEZA			000 048	OPERACION DE MONTAJE DE LA PIEZA			000 049	OPERACION DE MONTAJE DE LA PIEZA			000 050	OPERACION DE MONTAJE DE LA PIEZA			000 051	OPERACION DE MONTAJE DE LA PIEZA			000 052	OPERACION DE MONTAJE DE LA PIEZA			000 053	OPERACION DE MONTAJE DE LA PIEZA			000 054	OPERACION DE MONTAJE DE LA PIEZA			000 055	OPERACION DE MONTAJE DE LA PIEZA			000 056	OPERACION DE MONTAJE DE LA PIEZA			000 057	OPERACION DE MONTAJE DE LA PIEZA			000 058	OPERACION DE MONTAJE DE LA PIEZA			000 059	OPERACION DE MONTAJE DE LA PIEZA			000 060	OPERACION DE MONTAJE DE LA PIEZA			000 061	OPERACION DE MONTAJE DE LA PIEZA			000 062	OPERACION DE MONTAJE DE LA PIEZA			000 063	OPERACION DE MONTAJE DE LA PIEZA			000 064	OPERACION DE MONTAJE DE LA PIEZA			000 065	OPERACION DE MONTAJE DE LA PIEZA			000 066	OPERACION DE MONTAJE DE LA PIEZA			000 067	OPERACION DE MONTAJE DE LA PIEZA			000 068	OPERACION DE MONTAJE DE LA PIEZA			000 069	OPERACION DE MONTAJE DE LA PIEZA			000 070	OPERACION DE MONTAJE DE LA PIEZA			000 071	OPERACION DE MONTAJE DE LA PIEZA			000 072	OPERACION DE MONTAJE DE LA PIEZA			000 073	OPERACION DE MONTAJE DE LA PIEZA			000 074	OPERACION DE MONTAJE DE LA PIEZA			000 075	OPERACION DE MONTAJE DE LA PIEZA			000 076	OPERACION DE MONTAJE DE LA PIEZA			000 077	OPERACION DE MONTAJE DE LA PIEZA			000 078	OPERACION DE MONTAJE DE LA PIEZA			000 079	OPERACION DE MONTAJE DE LA PIEZA			000 080	OPERACION DE MONTAJE DE LA PIEZA			000 081	OPERACION DE MONTAJE DE LA PIEZA			000 082	OPERACION DE MONTAJE DE LA PIEZA			000 083	OPERACION DE MONTAJE DE LA PIEZA			000 084	OPERACION DE MONTAJE DE LA PIEZA			000 085	OPERACION DE MONTAJE DE LA PIEZA			000 086	OPERACION DE MONTAJE DE LA PIEZA			000 087	OPERACION DE MONTAJE DE LA PIEZA			000 088	OPERACION DE MONTAJE DE LA PIEZA			000 089	OPERACION DE MONTAJE DE LA PIEZA			000 090	OPERACION DE MONTAJE DE LA PIEZA			000 091	OPERACION DE MONTAJE DE LA PIEZA			000 092	OPERACION DE MONTAJE DE LA PIEZA			000 093	OPERACION DE MONTAJE DE LA PIEZA			000 094	OPERACION DE MONTAJE DE LA PIEZA			000 095	OPERACION DE MONTAJE DE LA PIEZA			000 096	OPERACION DE MONTAJE DE LA PIEZA			000 097	OPERACION DE MONTAJE DE LA PIEZA			000 098	OPERACION DE MONTAJE DE LA PIEZA			000 099	OPERACION DE MONTAJE DE LA PIEZA			000 100	OPERACION DE MONTAJE DE LA PIEZA		
HOJA DE RUTA		Nº PROYECTO PA0002																																																																																																																																																																																																																																																																																																																																																																																																																									
OPERACION	DESCRIPCION DE LA OPERACION	FECHA DE EJECUCION	FECHA DE ENTREGA																																																																																																																																																																																																																																																																																																																																																																																																																								
000 001	PREPARACION DE LA MATERIA PRIMA																																																																																																																																																																																																																																																																																																																																																																																																																										
000 002	OPERACION DE MONTAJE DE LA PIEZA																																																																																																																																																																																																																																																																																																																																																																																																																										
000 003	OPERACION DE MONTAJE DE LA PIEZA																																																																																																																																																																																																																																																																																																																																																																																																																										
000 004	OPERACION DE MONTAJE DE LA PIEZA																																																																																																																																																																																																																																																																																																																																																																																																																										
000 005	OPERACION DE MONTAJE DE LA PIEZA																																																																																																																																																																																																																																																																																																																																																																																																																										
000 006	OPERACION DE MONTAJE DE LA PIEZA																																																																																																																																																																																																																																																																																																																																																																																																																										
000 007	OPERACION DE MONTAJE DE LA PIEZA																																																																																																																																																																																																																																																																																																																																																																																																																										
000 008	OPERACION DE MONTAJE DE LA PIEZA																																																																																																																																																																																																																																																																																																																																																																																																																										
000 009	OPERACION DE MONTAJE DE LA PIEZA																																																																																																																																																																																																																																																																																																																																																																																																																										
000 010	OPERACION DE MONTAJE DE LA PIEZA																																																																																																																																																																																																																																																																																																																																																																																																																										
000 011	OPERACION DE MONTAJE DE LA PIEZA																																																																																																																																																																																																																																																																																																																																																																																																																										
000 012	OPERACION DE MONTAJE DE LA PIEZA																																																																																																																																																																																																																																																																																																																																																																																																																										
000 013	OPERACION DE MONTAJE DE LA PIEZA																																																																																																																																																																																																																																																																																																																																																																																																																										
000 014	OPERACION DE MONTAJE DE LA PIEZA																																																																																																																																																																																																																																																																																																																																																																																																																										
000 015	OPERACION DE MONTAJE DE LA PIEZA																																																																																																																																																																																																																																																																																																																																																																																																																										
000 016	OPERACION DE MONTAJE DE LA PIEZA																																																																																																																																																																																																																																																																																																																																																																																																																										
000 017	OPERACION DE MONTAJE DE LA PIEZA																																																																																																																																																																																																																																																																																																																																																																																																																										
000 018	OPERACION DE MONTAJE DE LA PIEZA																																																																																																																																																																																																																																																																																																																																																																																																																										
000 019	OPERACION DE MONTAJE DE LA PIEZA																																																																																																																																																																																																																																																																																																																																																																																																																										
000 020	OPERACION DE MONTAJE DE LA PIEZA																																																																																																																																																																																																																																																																																																																																																																																																																										
000 021	OPERACION DE MONTAJE DE LA PIEZA																																																																																																																																																																																																																																																																																																																																																																																																																										
000 022	OPERACION DE MONTAJE DE LA PIEZA																																																																																																																																																																																																																																																																																																																																																																																																																										
000 023	OPERACION DE MONTAJE DE LA PIEZA																																																																																																																																																																																																																																																																																																																																																																																																																										
000 024	OPERACION DE MONTAJE DE LA PIEZA																																																																																																																																																																																																																																																																																																																																																																																																																										
000 025	OPERACION DE MONTAJE DE LA PIEZA																																																																																																																																																																																																																																																																																																																																																																																																																										
000 026	OPERACION DE MONTAJE DE LA PIEZA																																																																																																																																																																																																																																																																																																																																																																																																																										
000 027	OPERACION DE MONTAJE DE LA PIEZA																																																																																																																																																																																																																																																																																																																																																																																																																										
000 028	OPERACION DE MONTAJE DE LA PIEZA																																																																																																																																																																																																																																																																																																																																																																																																																										
000 029	OPERACION DE MONTAJE DE LA PIEZA																																																																																																																																																																																																																																																																																																																																																																																																																										
000 030	OPERACION DE MONTAJE DE LA PIEZA																																																																																																																																																																																																																																																																																																																																																																																																																										
000 031	OPERACION DE MONTAJE DE LA PIEZA																																																																																																																																																																																																																																																																																																																																																																																																																										
000 032	OPERACION DE MONTAJE DE LA PIEZA																																																																																																																																																																																																																																																																																																																																																																																																																										
000 033	OPERACION DE MONTAJE DE LA PIEZA																																																																																																																																																																																																																																																																																																																																																																																																																										
000 034	OPERACION DE MONTAJE DE LA PIEZA																																																																																																																																																																																																																																																																																																																																																																																																																										
000 035	OPERACION DE MONTAJE DE LA PIEZA																																																																																																																																																																																																																																																																																																																																																																																																																										
000 036	OPERACION DE MONTAJE DE LA PIEZA																																																																																																																																																																																																																																																																																																																																																																																																																										
000 037	OPERACION DE MONTAJE DE LA PIEZA																																																																																																																																																																																																																																																																																																																																																																																																																										
000 038	OPERACION DE MONTAJE DE LA PIEZA																																																																																																																																																																																																																																																																																																																																																																																																																										
000 039	OPERACION DE MONTAJE DE LA PIEZA																																																																																																																																																																																																																																																																																																																																																																																																																										
000 040	OPERACION DE MONTAJE DE LA PIEZA																																																																																																																																																																																																																																																																																																																																																																																																																										
000 041	OPERACION DE MONTAJE DE LA PIEZA																																																																																																																																																																																																																																																																																																																																																																																																																										
000 042	OPERACION DE MONTAJE DE LA PIEZA																																																																																																																																																																																																																																																																																																																																																																																																																										
000 043	OPERACION DE MONTAJE DE LA PIEZA																																																																																																																																																																																																																																																																																																																																																																																																																										
000 044	OPERACION DE MONTAJE DE LA PIEZA																																																																																																																																																																																																																																																																																																																																																																																																																										
000 045	OPERACION DE MONTAJE DE LA PIEZA																																																																																																																																																																																																																																																																																																																																																																																																																										
000 046	OPERACION DE MONTAJE DE LA PIEZA																																																																																																																																																																																																																																																																																																																																																																																																																										
000 047	OPERACION DE MONTAJE DE LA PIEZA																																																																																																																																																																																																																																																																																																																																																																																																																										
000 048	OPERACION DE MONTAJE DE LA PIEZA																																																																																																																																																																																																																																																																																																																																																																																																																										
000 049	OPERACION DE MONTAJE DE LA PIEZA																																																																																																																																																																																																																																																																																																																																																																																																																										
000 050	OPERACION DE MONTAJE DE LA PIEZA																																																																																																																																																																																																																																																																																																																																																																																																																										
000 051	OPERACION DE MONTAJE DE LA PIEZA																																																																																																																																																																																																																																																																																																																																																																																																																										
000 052	OPERACION DE MONTAJE DE LA PIEZA																																																																																																																																																																																																																																																																																																																																																																																																																										
000 053	OPERACION DE MONTAJE DE LA PIEZA																																																																																																																																																																																																																																																																																																																																																																																																																										
000 054	OPERACION DE MONTAJE DE LA PIEZA																																																																																																																																																																																																																																																																																																																																																																																																																										
000 055	OPERACION DE MONTAJE DE LA PIEZA																																																																																																																																																																																																																																																																																																																																																																																																																										
000 056	OPERACION DE MONTAJE DE LA PIEZA																																																																																																																																																																																																																																																																																																																																																																																																																										
000 057	OPERACION DE MONTAJE DE LA PIEZA																																																																																																																																																																																																																																																																																																																																																																																																																										
000 058	OPERACION DE MONTAJE DE LA PIEZA																																																																																																																																																																																																																																																																																																																																																																																																																										
000 059	OPERACION DE MONTAJE DE LA PIEZA																																																																																																																																																																																																																																																																																																																																																																																																																										
000 060	OPERACION DE MONTAJE DE LA PIEZA																																																																																																																																																																																																																																																																																																																																																																																																																										
000 061	OPERACION DE MONTAJE DE LA PIEZA																																																																																																																																																																																																																																																																																																																																																																																																																										
000 062	OPERACION DE MONTAJE DE LA PIEZA																																																																																																																																																																																																																																																																																																																																																																																																																										
000 063	OPERACION DE MONTAJE DE LA PIEZA																																																																																																																																																																																																																																																																																																																																																																																																																										
000 064	OPERACION DE MONTAJE DE LA PIEZA																																																																																																																																																																																																																																																																																																																																																																																																																										
000 065	OPERACION DE MONTAJE DE LA PIEZA																																																																																																																																																																																																																																																																																																																																																																																																																										
000 066	OPERACION DE MONTAJE DE LA PIEZA																																																																																																																																																																																																																																																																																																																																																																																																																										
000 067	OPERACION DE MONTAJE DE LA PIEZA																																																																																																																																																																																																																																																																																																																																																																																																																										
000 068	OPERACION DE MONTAJE DE LA PIEZA																																																																																																																																																																																																																																																																																																																																																																																																																										
000 069	OPERACION DE MONTAJE DE LA PIEZA																																																																																																																																																																																																																																																																																																																																																																																																																										
000 070	OPERACION DE MONTAJE DE LA PIEZA																																																																																																																																																																																																																																																																																																																																																																																																																										
000 071	OPERACION DE MONTAJE DE LA PIEZA																																																																																																																																																																																																																																																																																																																																																																																																																										
000 072	OPERACION DE MONTAJE DE LA PIEZA																																																																																																																																																																																																																																																																																																																																																																																																																										
000 073	OPERACION DE MONTAJE DE LA PIEZA																																																																																																																																																																																																																																																																																																																																																																																																																										
000 074	OPERACION DE MONTAJE DE LA PIEZA																																																																																																																																																																																																																																																																																																																																																																																																																										
000 075	OPERACION DE MONTAJE DE LA PIEZA																																																																																																																																																																																																																																																																																																																																																																																																																										
000 076	OPERACION DE MONTAJE DE LA PIEZA																																																																																																																																																																																																																																																																																																																																																																																																																										
000 077	OPERACION DE MONTAJE DE LA PIEZA																																																																																																																																																																																																																																																																																																																																																																																																																										
000 078	OPERACION DE MONTAJE DE LA PIEZA																																																																																																																																																																																																																																																																																																																																																																																																																										
000 079	OPERACION DE MONTAJE DE LA PIEZA																																																																																																																																																																																																																																																																																																																																																																																																																										
000 080	OPERACION DE MONTAJE DE LA PIEZA																																																																																																																																																																																																																																																																																																																																																																																																																										
000 081	OPERACION DE MONTAJE DE LA PIEZA																																																																																																																																																																																																																																																																																																																																																																																																																										
000 082	OPERACION DE MONTAJE DE LA PIEZA																																																																																																																																																																																																																																																																																																																																																																																																																										
000 083	OPERACION DE MONTAJE DE LA PIEZA																																																																																																																																																																																																																																																																																																																																																																																																																										
000 084	OPERACION DE MONTAJE DE LA PIEZA																																																																																																																																																																																																																																																																																																																																																																																																																										
000 085	OPERACION DE MONTAJE DE LA PIEZA																																																																																																																																																																																																																																																																																																																																																																																																																										
000 086	OPERACION DE MONTAJE DE LA PIEZA																																																																																																																																																																																																																																																																																																																																																																																																																										
000 087	OPERACION DE MONTAJE DE LA PIEZA																																																																																																																																																																																																																																																																																																																																																																																																																										
000 088	OPERACION DE MONTAJE DE LA PIEZA																																																																																																																																																																																																																																																																																																																																																																																																																										
000 089	OPERACION DE MONTAJE DE LA PIEZA																																																																																																																																																																																																																																																																																																																																																																																																																										
000 090	OPERACION DE MONTAJE DE LA PIEZA																																																																																																																																																																																																																																																																																																																																																																																																																										
000 091	OPERACION DE MONTAJE DE LA PIEZA																																																																																																																																																																																																																																																																																																																																																																																																																										
000 092	OPERACION DE MONTAJE DE LA PIEZA																																																																																																																																																																																																																																																																																																																																																																																																																										
000 093	OPERACION DE MONTAJE DE LA PIEZA																																																																																																																																																																																																																																																																																																																																																																																																																										
000 094	OPERACION DE MONTAJE DE LA PIEZA																																																																																																																																																																																																																																																																																																																																																																																																																										
000 095	OPERACION DE MONTAJE DE LA PIEZA																																																																																																																																																																																																																																																																																																																																																																																																																										
000 096	OPERACION DE MONTAJE DE LA PIEZA																																																																																																																																																																																																																																																																																																																																																																																																																										
000 097	OPERACION DE MONTAJE DE LA PIEZA																																																																																																																																																																																																																																																																																																																																																																																																																										
000 098	OPERACION DE MONTAJE DE LA PIEZA																																																																																																																																																																																																																																																																																																																																																																																																																										
000 099	OPERACION DE MONTAJE DE LA PIEZA																																																																																																																																																																																																																																																																																																																																																																																																																										
000 100	OPERACION DE MONTAJE DE LA PIEZA																																																																																																																																																																																																																																																																																																																																																																																																																										

Trazabilidad documentada

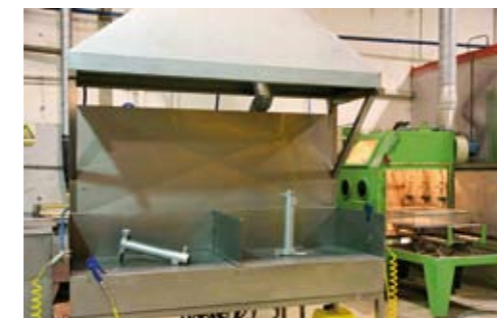

Departamento de acabado final

# Maquinaria

## Centro Multifunción



**OKUMA MULTUS B 300**  
15kW ø630 x 900mm  
15kW 630 x 230 x 900 mm

## Tornos Control Numérico



1 **BIGLIA B111**  
7,5 kW ø250 x 350 mm

1 **OKUMA LB 15**  
9 kW ø300 x 300 mm

1 **MORISEIKI SL 25**  
11,5 kW ø350 x 500 mm

1 **OKUMA LB 300 M**  
15 kW ø370 x 500

## Centros Horizontales y Verticales



1 **DECKEL-MAHO DMC 50-V.**  
15kW; 20 m/s; 650 x 400 x 450 mm.

1 **VICTOR VCENTER 70.**  
11,5kW; 32 m/s; 760 x 440 x 450 mm.

2 **OKUMA MF 46V.**  
17,5kW; 60 m/s; 760 x 440 x 450 mm

2 **QUASER 60-II.**  
11,5kW; 32 m/s; 500 x 500 mm.

1 **OKUMA 50 HB.**  
22kW 60 m/s; 500 x 500 mm.

1 **OKUMA MA 400.**  
22kW 60 m/s; 500 x 500 mm.

## Rectificados



1 **Surface HIDROPREC RSP 800**  
1000 x 500 x 500 mm

1 **Cylinder DANOBAT U500**  
ø 300 x 500 mm

1 **Cylinder PRECISSORI CNC 1000**  
ø 300 x 1000 mm

## Maquinaria Auxiliar



1 **Sierra de corte CNC**  
2 **Taladros profundos**  
1 **Lapeadora vertical**  
5 **Roscadoras manuales**  
**Maquinaria Universal**



# Tratamiento superficial

# Montaje



- 2 Vibrador circular
- 2 Chorreadoras
- 1 Cabina de limpieza
- 1 Electropulido
- 1 Lavadora de piezas
- Área de empaquetado y marcado

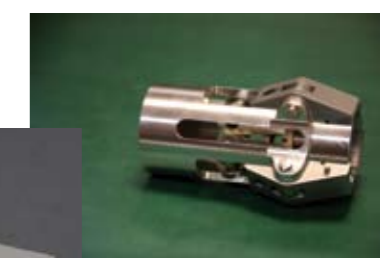
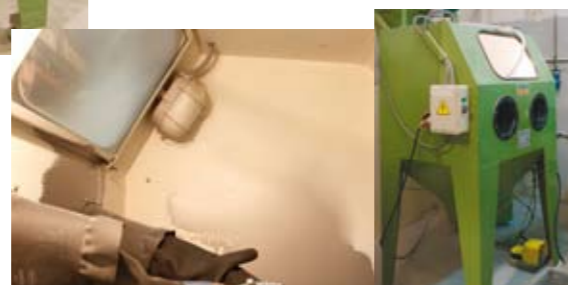

## IberPrecis S.L.

Polígono Pignatelli, nave 17

E-50410 Cuarte de Huerva

Tel: +34 976 503 727

Fax: +34 976 503 728

[iberprecis@iberprecis.com](mailto:iberprecis@iberprecis.com)

Zaragoza (España)



[www.iberprecis.com](http://www.iberprecis.com)